



## COOLING SYSTEM APPLICATION GUIDE



### Cooling System Tester SVTS272

- Requires less effort making it ideal for higher pressure systems
- Includes adapter TAB10052 essential to test many late model Fords



### Coolant Barrier

SVTS2000

Change a cooling system component WITHOUT draining the system!



### Cooling System Tester SVTS263A



### Cooling System Tester SVTS262C

## COOLING SYSTEM REFILLERS:



### SVTSRAD272A

For use with positive fit adapters



### SVTSRAD272U

No Adapters Necessary!

**More highly refined venturi and larger internal passages equals a faster, more complete fill.**



APPLICATION GUIDE AND PARTS LIST  
FOR COOLING SYSTEM ADAPTERS AND COOLING SYSTEM TOOLS

# Specifically for Large Trucks

## SVTSRAD372T

Truck Refiller



See back cover for diagram, descriptions, and part numbers

### A SNAP-ON EXCLUSIVE!

There is no better tool available to fill the large cooling systems found in large trucks.

How is this tool better?

### Better in four important ways:

1. New vacuum generator creates a higher vacuum more quickly. Not only is it faster, air volume remaining in the system is less than one quarter competitive units would leave giving the most complete fill possible.
2. Bottom connect gauge allows the tech to read the gauge from the shop floor and not have to climb on top of the vehicle or on a ladder to see it.
3. Larger coolant refill valve, increased passage diameters and larger hose and screen allows the tool to move coolant more efficiently.
4. Longer intake hose to accommodate the height of large trucks.

**The bottom line: A faster, more complete fill. It saves the technician time which saves him money and the job is done right the first time.**



### FOR LARGE TRUCKS: SVTA6100

Cooling system adapter set includes: TA4505, (fits traditional "B" size neck), TA27 (older Volvo Trucks), TA32A (2007- Kenworth, Freightliner, & Peterbilt), TA50 (most Volvo and late model Mack Trucks), TA54 (some Freightliner) and TA58 (2007-Dodge/Mercedes Sprinter Van). Combined with pump and TAB10036 adapter from SVTS272 or SVTS262C, it is able to pressure test the 8 filler necks found on modern large trucks.

Plastic box available separately as part number PBSVTA6000.



← Laminated adapter two sided application sheet included

- FITS RIGHT INSIDE THE CASE FOR QUICK REFERENCE -

# Consult Your Snap-on Franchisee for Availability of these Expanded Kits



## SVTA17000A:

An excellent display case including all adapters necessary for testing passenger vehicle cooling systems through 2016. Designed for the Snap-on Franchisee. Includes 17 adapters in a plastic display case containing: SVT262-28A, TA16B, TA18B, TA31A, TA34A, TA36GM, TA38C, TA41, TA44, TA46, TA48, TA52, TA56, TA245A, TA345A, TA445 and TA4503.

Plastic box available separately as part number PBSVTA1417.

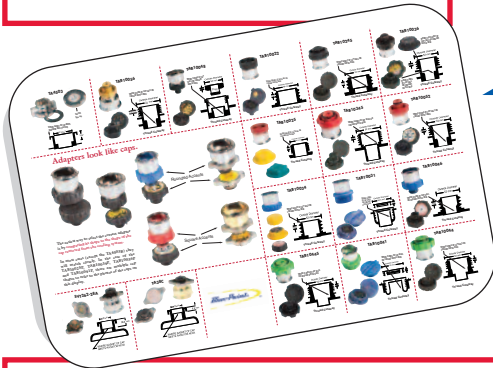

← Laminated adapter two sided application sheet included with both the SVTA17000A and Blue-Point SVTAB1400.

**- FITS RIGHT INSIDE THE CASE FOR QUICK REFERENCE -**



## BLUE-POINT® SVTAB1400:

Molded plastic box holds 14 composite cooling system adapters: TAB10022, TAB10025, TAB10031, TAB10034, TAB10041, TAB10044, TAB10046, TAB10048, TAB10052, TAB10056, TAB10245, TAB10345, TAB10445, and TA4503. Pump and adapters from SVTS272 or SVTS262C also will fit in box. This combination will pressure test the cooling systems of all modern cars and light trucks through 2016.

Plastic box available separately as part number PBSVTA1417.





**TAB10022**

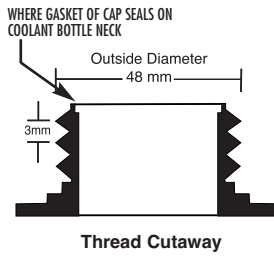

**APPLICATION:**

AUDI: models with male threads on filler neck

PORSCHE:

Boxster: 1997-2006

Cayman: 2006

911: 1999-current

SMART CAR:

Models 2008-current

VOLKSWAGEN:

models with male threads on filler neck of radiator or expansion tank



**TAB10025**

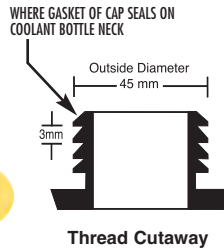

**APPLICATION:**

FERRARI/MASERATI: most models 2000-

JEEP: models with male threads on filler neck (1990-1994)

RENAULT: (1985-1997)

SAAB 900: (1978-1993)

-900 Convertible (1994)

-9000 (1986-1998)

STERLING: (1987-1991)

VOLVO: most models with threaded neck through 2004 (see page 17)

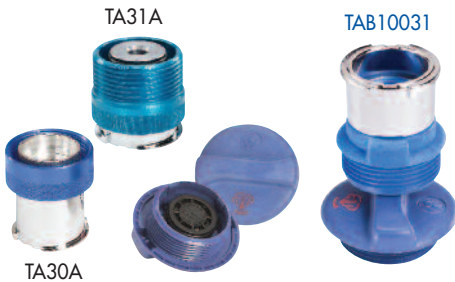

**TAB10031**

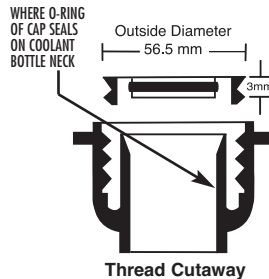

**APPLICATION:**

VOLKSWAGEN:

Most models with female threads on filler neck 1990-1998



**TA32A**

WHERE GASKET OF CAP SEALS ON COOLANT BOTTLE NECK

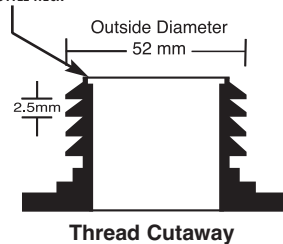

Pressure Relieving  
Cap (cars)

**APPLICATION:**

Some personal vehicles made by Buick, Cadillac, Chevrolet, Ford, GMC, Infiniti, Isuzu, Jaguar, Land Rover, Lincoln, Mazda, Mercedes, Mercury, Nissan, Oldsmobile and Pontiac.

Some large trucks made by Freightliner, International, Kenworth and Peterbilt

TA34A



TA246A

TAB10034



WHERE GASKET OF CAP SEALS ON COOLANT BOTTLE NECK

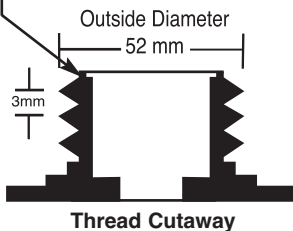

**APPLICATION:**

Some models of Cadillac, Chevrolet, Daewoo, Ford, Jaguar, Land Rover, Pontiac, Saab, Saturn and Suzuki



TAB10036



TA36GM



WHERE O-RING OF CAP SEALS ON COOLANT BOTTLE NECK

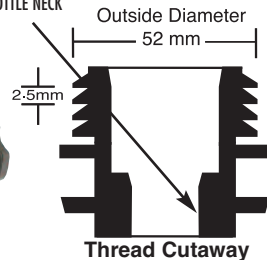

**APPLICATION:**

Some personal vehicles made by Buick, Cadillac, Chevrolet, Dodge, Ford, GMC, Hummer, Infiniti, Isuzu, Jaguar, Jeep, Land Rover, Lincoln, Mazda, Mercedes, Mercury, Nissan, Pontiac, RAM, Saab, Saturn and Suzuki.

Some large trucks made by Freightliner and International.



TA40

TA41

TAB10041



WHERE O-RING OF CAP SEALS ON COOLANT BOTTLE NECK

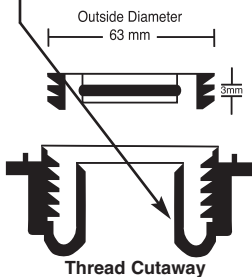

**APPLICATION:**

AUDI: A4 1996-current  
A6 1998-current  
A8 1997-current  
S4 2004-current  
TT 2000-current

BENTLEY: 2006-current

LAMBORGHINI: 2006-current

PORSCHE:

Boxster 2007-2013  
Cayenne 2003-2013  
Cayman 2007-2011  
Macan 2015-current  
Panamera 2010-current

VW: Most Models 1998 & newer

TA45



TA44

TAB10044



WHERE O-RING OF CAP SEALS ON COOLANT BOTTLE NECK

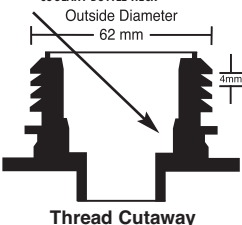

**APPLICATION:**

MERCEDES-BENZ: with threaded filler neck on expansion tank (except M-class, 1998-2005) (see page 15)

CHRYSLER: Crossfire 2004-2008

**TA47**      **TAB10046**      WHERE O-RING OF CAP SEALS ON COOLANT BOTTLE NECK

Outside Diameter  
52 mm

3mm

**APPLICATION:**  
Some models of Ford, Jaguar and Mazda

**Thread Cutaway**

**TA49**      **TAB10048**      WHERE O-RING OF CAP SEALS ON COOLANT BOTTLE NECK

Outside Diameter  
34 mm

3mm

(Cap)

**APPLICATION:**  
**LEXUS:**  
some models 2007 & later, see page 14  
**TOYOTA:**  
Celica 2000-current  
Spyder (MR2) 2000-current  
RAV4 2009-current  
Hybrid Synergy Drive  
Cooling System:  
Prius 2004-current  
Camry 2007-current  
Highlander 2006-current  
**SCION:**  
XB, 2008-current

**Thread Cutaway**

**TA52**      **TAB10052**      WHERE O-RING OF CAP SEALS ON COOLANT BOTTLE NECK

Outside Diameter  
50 mm

2.5mm

**APPLICATION:**  
**ASTON MARTIN**  
6.0 L, V-12 2015-current  
**FORD:**  
Many of the newer models (2011 and newer) will take the TA52/TAB10052. See pages 12 and 13 for specific models.  
**LAND ROVER:**  
LR-2 2008-current  
Range Rover  
Evoque 2012-current  
**MAZDA:**  
Mazda 3 2004-current  
**VOLVO:**  
most models 2004-current

**Thread Cutaway**

**TA56**      **TAB10056**      WHERE O-RING OF CAP SEALS ON COOLANT BOTTLE NECK

Outside Diameter  
40 mm

2.5mm  
2.0 mm

**APPLICATION:**  
**CHEVROLET:**  
Cobalt SS 2005-2007 (Supercharger Cooling System)  
Volt 2012- (Electric motor & battery cooling system)  
**SATURN:**  
Ion Redline 2004-2007 (Supercharger Cooling System)  
**CADILLAC:**  
STS 2006-2010 (Supercharger Cooling System)

**Thread Cutaway**

**TA58**      WHERE O-RING OF CAP SEALS ON COOLANT BOTTLE NECK

Outside Diameter  
45 mm

2.5 mm

**APPLICATION:**  
**DODGE:**  
Sprinter Van 2007-2010  
**MERCEDES:**  
Sprinter Van 2011-current

**Thread Cutaway**

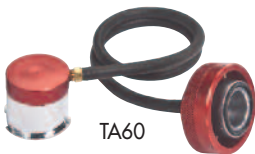

TA60

WHERE GASKET OF CAP MEETS RADIATOR NECK

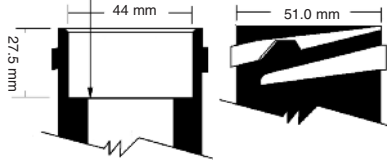

**APPLICATION:**

**PORSCHE:**  
 Boxster: 2006-2012  
 Cayman: 2006-2012  
 (Non-pressure relieving cap located in luggage compartment of vehicle).

TA63



TAB10063



TA26A

WHERE O-RING OF CAP SEALS ON COOLANT BOTTLE NECK

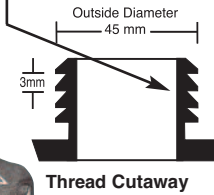

**APPLICATION:**

**BMW:**  
 Turbocharger Cooling Systems (all)

**MINI:**  
 Cooper 2002-current

*Comment: The TA63 and TAB10063 seal with an o-ring just like the cap from the system they test. In most cases the TA18B and TAB10025, which seal on the top rim will adequately seal such that pressure testing can be accomplished.*

**KTM MOTORCYCLES  
 BAYONET STYLE  
 ADAPTER**

TA67



TA67R



Adapter designed to fit around the gas tank so technician can test the cooling system without removing the gas tank.

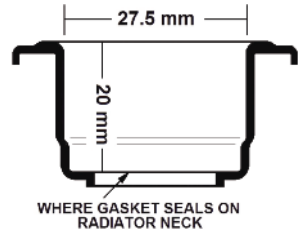

**KTM MOTORCYCLES  
 THREADED  
 ADAPTER**

TAB10069



WHERE GASKET OF CAP SEALS ON RADIATOR NECK

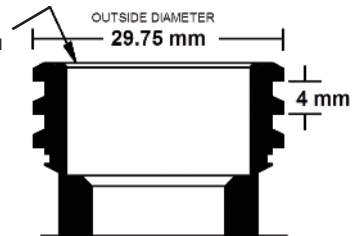

**APRILIA MOTORCYCLES  
 THREADED  
 ADAPTER**

TAB10070

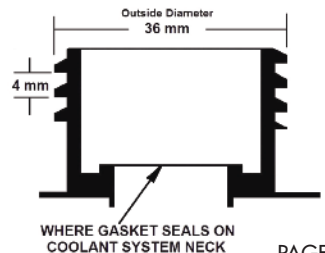



WHERE GASKET OF CAP SEALS ON COOLANT BOTTLE NECK

45 mm  
THREAD DIAMETER

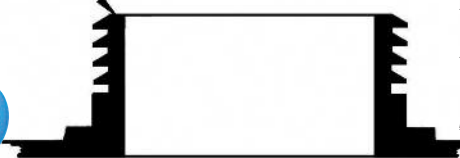

COOLING SYSTEM TANK  
THREAD CUTAWAY

**APPLICATION:**

ALFA ROMEO:

Some models with threaded filler neck

DODGE:

ProMaster 2015-current

FIAT:

Model 500: Some versions with threaded filler necks

MASERATI:

Ghibli S Q4 2015-current

TAB10072

TAB10074



TA23A

WHERE O-RING OF CAP SEALS ON COOLANT BOTTLE NECK

80 mm  
Outside diameter  
48 mm

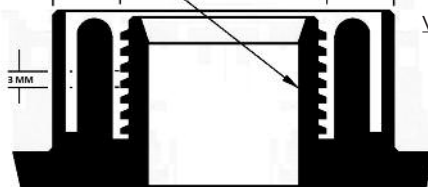

**APPLICATION:**

BENTLEY

Some Models

VOLKSWAGEN

Sharan (EU)

Phaeton 2004-2006 (US)

TAB10078

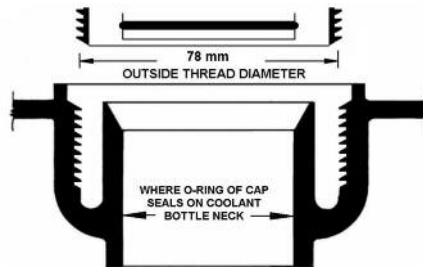

**APPLICATION:**

PORSCHE

Some Models

TA246A



TA245A

TAB10245



WHERE GASKET OF CAP SEALS ON COOLANT BOTTLE NECK

Outside Diameter  
52 mm

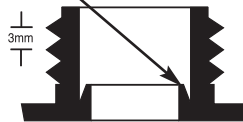

Thread Cutaway

**APPLICATION:**

BMW: models with threaded filler necks (up to 1987)

325: up to 1991

525: up to 1993

MERKUR SCORPIO:

(1987-1989)

Comments:  
Rubber gasket seals on "shelf" inside expansion tank neck

TA345A



TA346A

TAB10345



WHERE GASKET OF CAP SEALS ON COOLANT BOTTLE NECK

Outside Diameter  
52 mm

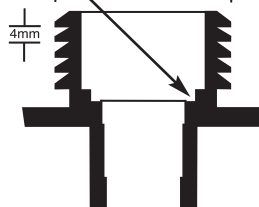

Thread Cutaway

**APPLICATION:**

BMW: Most Models, 1988-2008

LAND ROVER:

Some models with male threads on filler neck (see page 14)

Discovery 1999-2004

Range Rover 1996-2006

Comments:

Rubber gasket seals on "shelf" inside expansion tank neck



TA445

TAB10445



WHERE GASKET OF CAP SEALS ON COOLANT BOTTLE NECK

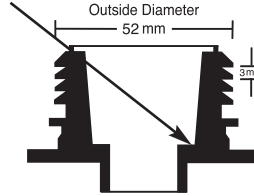

Thread Cutaway

**APPLICATION:**

**BMW:**  
(Most models, 2007-current)

- 3-Series 2006-current
- 5-Series 2005-current
- 6-Series 2005-current

**FORKLIFTS - MOTORCYCLES - TOYOTA SIENNA VAN**

Remote adapter allows pressure pump or vacuum refiller to be installed in various low overhead applications.

Most motorcycles, including the Harley Davidson liquid cooled models, use this configuration.

SVT262-28A

ROUNDED EARS

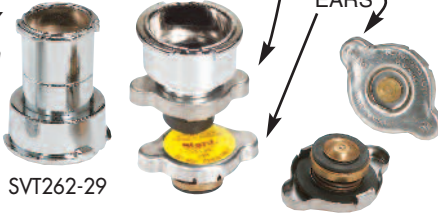

SVT262-29

**SVT262-28R Remote Adapter**

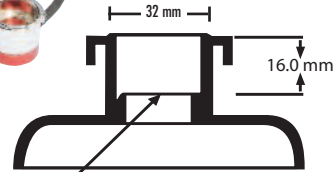

WHERE GASKET OF CAP MEETS RADIATOR NECK



TA39A

TA38C

SQUARE EARS

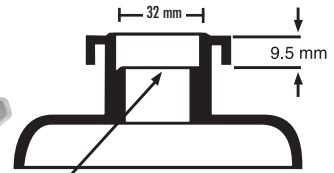

WHERE GASKET OF CAP MEETS RADIATOR NECK

Comments: The SVT262-29/SVT262-28/SVT262-28A and the TA39A/TA388/TA38C have applications too numerous to list here. See Application Guide pp 11-17. These adapter sets are quite similar, but the SVT262-29/SVT262-28/SVT262-28A is a deeper neck than the TA39A/TA388/TA38C. See drawings above, right. **Note: SVT262-28A & TA38C are shaped to resemble caps from system to be tested.**



SVT262-21

SVT26233

WHERE GASKET OF CAP MEETS RADIATOR NECK

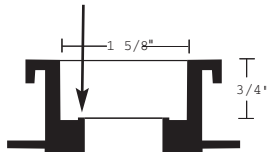

Thread Cutaway

**APPLICATION:**

Most passenger vehicles through the mid 1980's have this radiator neck and many still do today. This is the configuration onto which the pump attaches directly.

For Necks 1" deep use 1/4" thick SVT262-22 spacer washer to compensate.

**LARGE TRUCKS / BUSES / HEAVY EQUIPMENT**



TAB10084

WHERE GASKET OF CAP SEALS ON COOLANT BOTTLE NECK

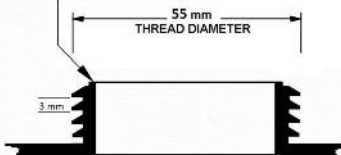

COOLING SYSTEM TANK THREAD CUTAWAY

**APPLICATION:**

**KENWORTH:**  
2015-current  
T270  
T370

# LARGE TRUCKS / BUSES / HEAVY EQUIPMENT (CONTINUED)



TAB10076

Note: Cap and adapter have 3 tabs

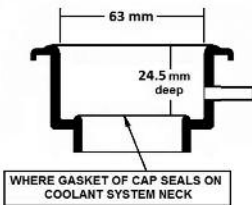

Thread Cutaway

**APPLICATION:**  
LIEBHERR CRANE:  
Some models  
VAN HOOL BUS:  
Some models

TA4504

TA450A SET

TA450A  
Type cap

TA4505



WHERE GASKET OF CAP MEETS RADIATOR NECK (TA4503)

WHERE GASKET OF CAP MEETS RADIATOR NECK (TA450A)

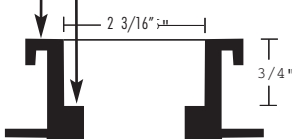

Thread Cutaway



TA4503

**PART #TA4503:** GM adapter kit tests pressure on "closed cooling systems" on GM 2.5L "X" body cars and 1.8L "J" body cars

**PART #TA450A:**

Truck adapter kit for trucks with "B" size 2 11/16" O.D. filler neck



TAB10027



WHERE GASKET OF CAP SEALS ON COOLANT BOTTLE NECK

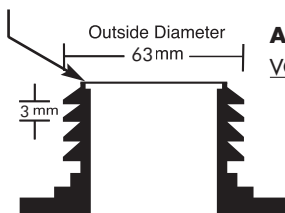

Thread Cutaway

**APPLICATION:**  
VOLVO:

Large Trucks with 63mm x 3mm thread on filler neck



TAB10022



WHERE GASKET OF CAP SEALS ON COOLANT BOTTLE NECK

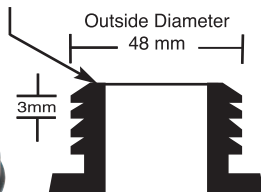

Thread Cutaway

**APPLICATION:**  
VOLVO:

Large Trucks with 48mm x 3mm male thread on filler neck  
**MACK TRUCKS:**  
2008 and later with 48mm x 3mm threads on filler neck



TAB10054



WHERE GASKET OF CAP SEALS ON COOLANT BOTTLE NECK

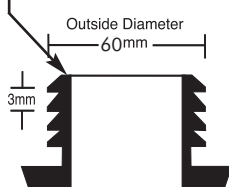

Thread Cutaway

**APPLICATION:**  
FREIGHTLINER:

Trucks with 60mm x 3mm male thread on filler neck

# COOLING SYSTEM ADAPTERS

Make/Model/Year	Cooling System Adapter	Cap Adapter
<b>ACURA</b>		
Models with 16mm deep filler neck, see page 9	SVT262-28/28A	SVT262-29
Models with 9.5mm deep filler neck, see page 9	TA388/TA38C	TA39A
<b>ASTON MARTIN</b>		
6.0 L, V-12 2015-current	TA52/TAB10052	TA53
<b>AUDI</b>		
Models with male threads on filler neck of exp. tank	TA16B/TAB10022	TA23A
Models with female threads on filler neck of exp. tank	TA41/TAB10041	TA40
<b>BLUEBIRD BUS</b>		
Late model Thomas Built buses	TA36GM/TAB10036	TA37
<b>BMW</b>		
Models with threaded filler neck		
Up to 1987	TA245A/TAB10245	TA246A
Most 1988-2007	TA345A/TAB10345	TA346A
Most 2007 - current	TA445/TAB10445	TA446
Model 325		
1988-1991	TA245A/TAB10245	TA246A
Model 535		
1989-1993	TA245A/TAB10245	TA246A
1 Series		
2008-current	TA445/TAB10445	TA446
3 Series		
1990-2006	TA345A/TAB10345	TA346A
2006-current	TA445/TAB10445	TA446
5 Series		
1989-2004	TA345A/TAB10345	TA346A
2005-current	TA445/TAB10445	TA446
Turbocharger Cooling Sys (all)	TA63/TAB10063▲	TA26A
6 Series		
2004-current	TA445/TAB10445	TA446
Turbocharger Cooling Sys (all)	TA63/TAB10063▲	TA26A
7 Series		
1994-2008	TA345A/TAB10345	TA346A
2008-current	TA445/TAB10445	TA446
Turbocharger Cooling Sys (all)	TA63/TAB10063▲	TA26A
X3		
2004-7/2009	TA345A/TAB10345	TA26A
7/2009	TA445/TAB10445	TA446
X5		
2000-2008	TA345A/TAB10345	TA346A
2009-current	TA445/TAB10445	TA446
Turbocharger Cooling Sys (all)	TA63/TAB10063▲	TA26A
X6		
2008-current	TA445/TAB10445	TA446
Turbocharger Cooling Sys (all)	TA63/TAB10063▲	TA26A

▲ TA63/TAB10063 seals the same way the radiator cap seals but the TA18B/TAB10025 will work in most applications.

Make/Model/Year	Cooling System Adapter	Cap Adapter
<b>BMW (CONTINUED)</b>		
Z3		
2002	TA345A/TAB10345	TA346
Z4		
2003-2008	TA345A/TAB10345	TA346A
2009-current	TA445/TAB10445	TA446
Z8		
2003	TA345A/TAB10345	TA346A
<b>BUICK</b>		
All Models w/male threads on filler neck except as noted below	TA36GM/TAB10036	TA37
Roadmaster		
1994-1996	TA36GM/TAB10036**	TA33A
Skyhawk		
1982-1987 1.8L & 2.0L	TA4503	
Skylark		
1982-1988 2.5L	TA4503	
1992-1998	TA36GM/TAB10036**	TA33A
Somerset		
1985-1987 2.5L	TA4503	
<b>CADILLAC</b>		
All Models w/male threads on filler neck except as noted below	TA36GM/TAB10036	TA37
Catera		
1997-2001	TA34A/TAB10034	TA246A
Fleetwood		
1994-1996	TA36GM/TAB10036**	TA33A
Seville		
1998-2004	TA36GM/TAB10036**	TA33A
STS		
2005-2010		
Engine Cooling System	TA36GM/TAB10036	TA37
Supercharger Cooling System	TA56/TAB10056	TA57
<b>CHEVROLET</b>		
All Models w/ male threads on filler neck except as noted below	TA36GM/TAB10036	TA37
Aveo		
2004-2011	TA34A/TAB10034	TA246A
Beretta		
1992-1996	TA36GM/TAB10036**	TA33A
Caprice		
1994-1996	TA36GM/TAB10036**	TA33A
Cavalier		
1995-1998	TA36GM/TAB10036**	TA33A
1999-2005	TA36GM/TAB10036	TA37
Citation		
1982-1985 2.5L	TA4503	
Cobalt		
2005-2010		
Engine Cooling System	TA36GM/TAB10036	TA37
Supercharger Cooling System	TA56/TAB10056	TA57
Corsica		
1992-1996	TA36GM/TAB10036**	TA33A

\*\*If TA36GM/TAB10036 "Stem" does not fit into cooling system neck, you might need to use TA32A

# COOLING SYSTEM ADAPTERS

Make/Model/Year	Cooling System Adapter	Cap Adapter
<b>CHEVROLET (CONTINUED)</b>		
Impala		
1994-1996	TA36GM/TAB10036**	TA33A
2004-current	TA36GM/TAB10036	TA37
Lumina		
1990-1992	TA4503	
Malibu		
1997-1998	TA36GM/TAB10036**	TA33A
1999-current	TA36GM/TAB10036	TA37
Metro		
1998-2001	TA38B/TA38C	TA39A
Nova		
1985-1988	SVT262-28/28A	SVT262-29
Prizm		
1998-2002	TA38B/TA38C	TA39A
Spectrum		
1985-1989	SVT262-28/28A	SVT262-29
Sprint		
1985-1988	SVT262-28/28A	SVT262-29
Tracker		
1998-2004	TA38B/TA38C	TA39A
Volt		
2012-current		
Electric Motor	TA56/TAB10056	TA57
Battery System	TA56/TAB10056	TA57
Gasoline Engine	TA36GM/TAB10036	TA37
<b>CHRYSLER/DODGE/EAGLE/PLYMOUTH</b>		
2000 GTX		
1989-1990	SVT262-28/28A	SVT262-29
Avenger		
1995-1999	SVT262-28/28A	SVT262-29
Colt		
1984-1993	SVT262-28/28A	SVT262-29
1992-1994 (some models)	TA38B/TA38C	TA39A
Conquest		
1984-1989	SVT262-28/28A	SVT262-29
Crossfire		
2004-2008	TA44/TAB10044	TA45
Dart		
2013-current	TA36GM/TAB10036	TA37
Laser/Talon		
1990-1998	SVT262-28/28A	SVT262-29
Promaster		
2014-current	TA72/TAB10072*	TA26A
RAM 50 Pickup		
1987-1993	SVT262-28/28A	SVT262-29
RAM Pick-up		
2013 - (6.7L)	TA36GM/TAB10036	TA37
Sebring		
2003-2005 6c 3.0L & 4c 2.4L	TAB38B/TA38C	TA39A
2001, 2002-2006	none	SVT262-21
Sprinter Van		
2007-2010	TA58	TA59

\*\*If TA36GM/TAB10036 "stem" with o-ring will not fit into cooling system neck, the TA32A may be required.

Make/Model/Year	Cooling System Adapter	Cap Adapter
<b>CHRYSLER/DODGE/EAGLE/PLYMOUTH</b>		
Stealth		
1991-1996	SVT262-28/28A	SVT262-29
Stratus (3.0 liter only)		
2001-2006	TA38B/TA38C	TA39A
Summit		
1989-1992	SVT262-28/28A	SVT262-29
1992-1996	TA38B/TA38C	TA39A
Talon		
1990-1998	SVT262-28/28A	SVT262-29
<b>DAEWOO</b>		
All		
1999-2002	TA34A/TAB10034	TA246A
<b>FERRARI</b>		
Most Models		
2000-current	TA18B/TAB10025	TA26A
<b>FORD/LINCOLN/MERCURY</b>		
All Models w/male threads on filler neck except as noted below	TA36GM/TAB10036**	TA33A
Aspire		
1994-1997	SVT262-28/28A	SVT262-29
C-Max		
2013-current	TA52/TAB10052	TA53
Contour		
1995-1997	TA34A/TAB10034	TA246A
1998-2000	TA46/TAB10046	TA47
Cougar/Thunderbird		
1989-1992	SVT262-28/28A	SVT262-29
1993-1997 V8	TA36GM/TAB10036**	TA33A
1993-1997 V6	SVT262-28/28A	SVT262-29
Edge		
2015-current	TA52/TAB10052	TA53
Escape		
2001-2012	TA46/TAB10046	TA47
2013-current	TA52/TAB10052	TA53
Escort/Tracer		
1991-current	SVT262-28/28A	SVT262-29
Explorer/Mountaineer/Aviator		
1995-2002	SVT262-28/28A	SVT262-29
2002-current	TA36GM/TAB10036**	TA33A
F-150 Pick up		
2015-current	TA52/TAB10052	TA53
Festiva		
1988-1993	SVT262-28/28A	SVT262-29
Fiesta		
2011-current	TA52/TAB10052	TA53
Focus		
2000-2004	TA34A/TAB10034	TA246A
2005-2007	TA36GM/TAB10036**	TA33A
2008-2011	SVT262-28/28A	SVT262-29
2012-current	TA52/TAB10052	TA53
Fusion		
2013-current	TA52/TAB10052	TA53
LS		
2002-2006	TA34A/TAB10034	TA246A

# COOLING SYSTEM ADAPTERS

Make/Model/Year	Cooling System Adapter	Cap Adapter
<b>FORD/LINCOLN/MERCURY</b>		
MKC 2015-current	TA52/TAB10052	TA53
Mustang V8, 1996-2014	TA36GM/TAB10036**	TA33A
V6, 1997-2004	SVT262-28/28A	SVT262-29
V6, 2005-current	TA36GM/TAB10036**	TA33A
V8 2015-current	TA52/TAB10052	TA53
Probe 1989-1997	SVT262-28/28A	SVT262-29
Ranger Pickup 1995- (non threaded neck)	SVT262-28/28A	SVT262-29
2002- (threaded neck)	TA36GM/TAB10036**	TA33A
Super Duty Pickup expansion tank 2012-current	TA36GM/TAB10036**	
Tempo/Topaz 1992-1994	SVT262-28/28A	SVT262-29
Thunderbird 1989-1993 (All)	SVT262-28/28A	SVT262-29
1994-1997 (V6)	SVT262-28/28A	SVT262-29
1994-1997 (V8)	TA36GM/TAB10036**	TA33A
2002-2004 (V8)	TA36GM/TAB10036**	TA33A
Transit 2010-2012	TA34A/TAB10034	TA246A
2013-current	TA52/TAB10052	TA53
Villager 1993-2002	SVT262-28/28A	SVT262-29
Windstar 1995-2000	SVT262-28/28A	SVT262-29
2000-2003	TA36GM/TAB10036**	TA33A
ZX2 2001-2003	SVT262-28/28A	SVT262-29
<b>FREIGHTLINER</b>		
Trucks with 60mm x 3mm male thread	TA54/TAB10054	
52mm x 2.5mm male thread:		
Cascadia 2007-current	TA32A	TA33A
Century, Columbia 2002-current	TA36GM/TAB10036	TA37
<b>GEO</b>		
Metro 1989-1994	SVT262-28/28A	SVT262-29
1995-1998	TA38B/TA38C	TA39A
Prizm 1989-1992	SVT262-28/28A	SVT262-29
1993-2002	TA38B/TA38C	TA39A
Storm 1990-1993	SVT262-28/28A	SVT262-29
Tracker 1989-1993	SVT262-28/28A	SVT262-29
1994-2004	TA38B/TA38C	TA39A

\*\*If TA36GM/TAB10036 "stem" with o-ring will not fit into cooling system neck, the TA32A may be required.

Make/Model/Year	Cooling System Adapter	Cap Adapter
<b>GMC</b>		
All Models w/male threads on filler neck	TA36GM/TAB10036	TA37
<b>HONDA</b>		
Models with 16mm deep filler neck, see page 9	SVT262-28/28A	SVT262-29
Models with 9.5mm deep filler neck, see page 9	TA38B/TA38C	TA39A
<b>HUMMER</b>		
All Models with male threads on filler neck	TA36GM/TAB10036	TA37
<b>HYUNDAI</b>		
All models 1987-current	SVT262-28/28A	SVT262-29
<b>INTERNATIONAL</b>		
466 Engine with male threads on filler neck 1994-1998	TA36GM/TAB10036**	TA33A
<b>INFINITI</b>		
All Models with Non-Threaded Small Cooling System Caps (see page 9)	SVT262-28/28A	SVT262-29
QX56 2004-2009	TA36GM/TAB10036**	TA33A
2010-current	SVT262-28/28A	SVT262-29
<b>ISUZU</b>		
All models except as noted below 1985-2009	SVT262-28/28A	SVT262-29
Amigo 1999-2000 (L-4 only)	TA38B/TA38C	TA39A
Ascender 2002-2009	TA36GM/TAB10036	TA37
i280 2006	TA36GM/TAB10036	TA37
i290 2007-2008	TA36GM/TAB10036	TA37
i350 2006	TA36GM/TAB10036	TA37
i370 2007-2008	TA36GM/TAB10036	TA37
Oasis 1996-1999	TA38B/TA38C	TA39A
Rodeo 1998-2003 (L-4 only)	TA38B/TA38C	TA39A

# COOLING SYSTEM ADAPTERS

<i>Make/Model/Year</i>	<i>Cooling System Adapter</i>	<i>Cap Adapter</i>
<b>JAGUAR</b>		
Models with male threads on filler neck		
1990-1994 F-Type	TA34A/TAB1034	TA246A
2013-current XF	TA36GM/TAB10036**	TA33A
2009-current XJ8	TA36GM/TAB10036**	TA33A
1998-2003 2004-2009 XK8	TA46/TAB10046 TA36GM/TAB10036**	TA47 TA33A
1997-2004, 2006 S-Type	TA46/TAB10046	TA47
2000-2008 X-Type	TA36GM/TAB10036**	TA33A
2002-current	TA34A/TAB10034	TA246A
<b>JEEP</b>		
Models with male threads on filler neck		
1987-1990 Cherokee	TA188/TAB10025	TA26A
2014-current Renegade	TA36GM/TAB10036	TA37
2015-current	TA36GM/TAB10036	TA37
<b>JOHN DEERE TRACTORS</b>		
Most model #'s over 3000 with 48mm O.D. male threads on filler neck	TA16B/TAB1022	TA23A
Most model #'s under 3000 with 52mm O.D. male threads on filler neck	N/A-consult factory	N/A
<b>KENWORTH</b>		
Some Models 2007-current T270, T370	TA32A	TA33A
2015-current	TAB10084	
<b>KIA</b>		
Models with 16mm deep filler neck, see page 7	SVT262-28/28A	SVT262-29

<i>Make/Model/Year</i>	<i>Cooling System Adapter</i>	<i>Cap Adapter</i>
<b>LAND ROVER</b>		
Defender 1993-1995, 1997		
Discovery 1998	TA34A/TAB10034	TA246A
1999-2004 Freelander	TA345A/TAB10345	TA346A
2002-current LR2	TA188/TAB10025	TA26A
2008-current LR3	TA52/TAB10052	TA53
2005-2009 LR4	TA36GM/TAB10036**	TA33A
2010-current Range Rover	TA36GM/TAB10036**	TA33A
1988-1994 1995-2005 2006-current Range Rover Evoque	TA34A/TAB10034 TA345A/TAB10345 TA36GM/TAB10036**	TA246A TA346A TA33A
2012-current	TA52/TAB10052	TA53
<b>LEXUS</b>		
Models with 16mm deep filler neck, see page 9	SVT262-28/28A	SVT262-29
Models with 9.5mm deep filler neck, see page 9	TA388/TA38C	TA39A
Models with Threaded Caps: GS 460 2008-current HS 250h 2010-current IS F 2008-current LS 2007-current	TA48/TAB10048 TA48/TAB10048 TA48/TAB10048 TA48/TAB10048 TA48/TAB10048	TA49 TA49 TA49 TA49
<b>LIEBHERR CRANE</b>		
Some Models	TAB10076	
<b>MACK</b>		
Late models with male threads on filler neck	TA50/TAB10022	TA23A
<b>MASERATI</b>		
Most Models 2000-current Ghibli S Q4	TA188/TAB10025	TA26A
2015-current	TA72/TAB10072*	TA26A

\*\*If TA36GM/TAB10036 "stem" with o-ring will not fit into cooling system neck, the TA32A may be required.

\*TA188/TAB10025 may also work.

# COOLING SYSTEM ADAPTERS

Make/Model/Year	Cooling System Adapter	Cap Adapter
<b>MAZDA</b>		
Models with 16mm deep filler neck, see page 9	SVT262-28/28A	SVT262-29
Models with 9.5mm deep filler neck, see page 9	TA38B/TA38C	TA39A
Models with Threaded Caps:		
B2300 Pickup		
1994-1997	none	SVT262-21
2001-2009	TA36GM/TAB10036**	TA33A
Tribute		
2001-2011	TA46/TAB10046	TA47
Mazda 3		
2004-current	TA52/TAB10052	TA53
Mazda 6		
2003-current	TA36GM/TAB10036	TA37
<b>MERCEDES</b>		
Models with threaded neck except M-Class below	TA44/TAB10044	TA45
M-Class with threaded neck		
1998-2005	TA36GM/TAB10036**	TA33A
M-Class		
2006-current	TA44/TAB10044	TA45
Sprinter Van		
2011-current	TA58	TA59
<b>MERKUR</b>		
Scorpio		
1987-1989	TA245A/TAB10245	TA246A
<b>MINI</b>		
Cooper S Model		
2002-current	TA63/TAB10063▲	TA26A
<b>MITSUBISHI</b>		
Models with 16mm deep filler neck, see page 9	SVT262-28/28A	SVT262-29
Models with 9.5mm deep filler neck, see page 9	TA38B/TA38C	TA39A
<b>NISSAN</b>		
All models with non-threaded small cooling system caps		
1987-current	SVT262-28/28A	SVT262-29
Armada/Titan		
2004-2009	TA36GM/TAB10036**	TA33A
2010-current	SVT262-28/28A	SVT262-29

▲TA63/TAB10063 seals the same way the radiator cap seals but the TA18B/TAB10025 will work in most applications.

\*\*If TA36GM/TAB10036 "stem" with o-ring will not fit into cooling system neck, the TA32A may be required.

Make/Model/Year	Cooling System Adapter	Cap Adapter
<b>OLDSMOBILE</b>		
Achieva		
1992-1998	TA36GM/TAB10036**	TA33A
Alero		
1999-2004	TA36GM/TAB10036	TA37
Aurora		
1995-1999	TA36GM/TAB10036**	TA33A
Bravada		
2002-2004	TA36GM/TAB10036	TA37
Cutlass		
1997-1998	TA36GM/TAB10036**	TA33A
1999	TA36GM/TAB10036	TA37
Intrigue		
1999	TA36GM/TAB10036**	TA33A
2000-2002	TA36GM/TAB10036	TA37
<b>PETERBILT TRUCKS</b>		
Some Models 2007-current	TA32A	TA33
<b>PONTIAC</b>		
Fiero		
1984-1988	TA4503	
Firebird		
1999-2002	TA36GM/TAB10036	TA37
G3		
2009-2010	TA34A/TAB10034	TA246A
G5		
2007-2010	TA36GM/TAB10036	TA37
G6		
2005-2010	TA36GM/TAB10036	TA37
Grand Am		
1985-1988	TA4503	
1992-1998	TA32A	TA33A
1999-2005	TA36GM/TAB10036	TA37
Grand Prix		
2004-2008	TA36GM/TAB10036	TA37
GTO		
2004-2006	TA36GM/TAB10036**	TA33A
Le Mans		
1988-1993	TA34A/TAB10034	TA246A
Montana		
1999-2006	none	SVT262-21
2007-2009	TA36GM/TAB10036	TA37
Optima		
1988-1991	TA36GM/TAB10036**	TA33A
Solstice		
2006-2009	TA36GM/TAB10036	TA37
Sunbird		
1982-1992	TA4503	
Sunburst		
1985-1988	SVT262-28/28A	SVT262-29
Sunfire		
1995-1998	TA32A	TA33A
1999-2005	TA36GM/TAB10036	TA37
Vibe		
2003-2010	TA38B/TA38C	TA39A

# COOLING SYSTEM ADAPTERS

<i>Make/Model/Year</i>	<i>Cooling System Adapter</i>	<i>Cap Adapter</i>
<b>PORSCHE</b>		
911		
1999-current	TA16B/TAB10022	TA23A
Boxster		
1997-2006	TA16B/TAB10022	TA23A
2007-2013	TA41/TAB10041	TA40
2015-current (in luggage compartment)	TAB10078	
Boxster/Cayman		
2007-2013		
3 prong access cap	TA60	
Cayenne		
2003-current	TA41/TAB10041	TA40
Cayman		
2006	TA16B/TAB10022	TA23A
2007-2011	TA41/TAB10041	TA40
2014-current (in luggage compartment)	TAB10078	
Macan		
2015-current	TA41/TAB10041	TA40
Panamera		
2010-current	TA41/TAB10041	TA40
<b>RENAULT</b>		
All models		
1985-1987	TA18B/TAB10025	TA26A
<b>SAAB</b>		
900		
1978-1993	TA18B/TAB10025	TA26A
1994-1998	TA34A/TAB10034	TA246A
900 Convertible		
1994	TA18B/TAB10025	TA26A
9000		
1986-1998	TA18B/TAB10025	TA26A
9-3		
1999-2003	TA34A/TAB10034	TA246A
2004-2010	TA36GM/TAB10036**	TA37
9-5		
1999-2008	TA34A/TAB10034	TA246A
9-7 X		
2005-2009	TA36GM/TAB10036	TA37
<b>SATURN</b>		
All models except as below		
1990-1998	TA32A	TA33A
1999-current	TA36GM/TAB10036	TA37
L - Series		
2000-2005	TA34A/TAB10034	TA246A
Vue		
2002	TA34A/TAB10034	TA246A
2003-2009	TA36GM/TAB10036	TA37
Ion Redline		
2004-2009	TA36GM/TAB10036	
Engine Cooling System		
Supercharger Cooling System	TA56/TAB10056	TA37 TA57

<i>Make/Model/Year</i>	<i>Cooling System Adapter</i>	<i>Cap Adapter</i>
<b>SCION</b>		
All models		
2004-current	TA38B/TA38C	TA39A
XB		
2008-current	TA48/TAB10048	TA49
<b>SMART</b>		
All models		
2008-current	TA16B/TAB10022	TA23A
<b>STERLING</b>		
All models		
1987-1991	TA18B/TAB10025	TA26A
<b>SUBARU</b>		
Models with 16mm deep filler neck, see page 9	SVT262-28/28A	SVT262-29
Models with 9.5mm deep filler neck, see page 9	TA38B/TA38C	TA39A
<b>SUZUKI</b>		
Models with 16mm deep filler neck, see page 9	SVT262-28/28A	SVT262-29
Models with 9.5mm deep filler neck, see page 9	TA38B/TA38C	TA39A
Forenza		
2004-2008	TA34A/TAB10034	TA246A
Reno		
2005-2008	TA34A/TAB10034	TA246A
Verona		
2004-2006	TA34A/TAB10034	TA246A
XL 7		
2007-2009	TA36GM/TAB10036	TA37



# COOLING SYSTEM ADAPTERS

Make/Model/Year	Cooling System Adapter	Cap Adapter
<b>TOYOTA</b>		
Models with Non-Threaded Cooling System Caps: Models with 16mm deep filler neck, see page 9 Models with 9.5mm deep filler neck, see page 9	SVT262-28/28A  TA388/TA38C	SVT262-29  TA39A
Models with Threaded Cooling System Caps: Avalon 2013- Celica 2000-2005 MR2 Spyder 2000-2005 RAV4 2009-current Sienna (see page 9) 1998-2006 Hybrid Synergy Drive Cooling System: Camry 2007-current Highlander 2006-current Prius 2004-current	TA48/TAB10048  TA48/TAB10048  TA48/TAB10048  TA48/TAB10048  SVT262-28R	TA49  TA49  TA49  SVT262-29
<b>TRUCKS</b>		
Vehicles with large fill ("B") neck (2 11/16") see page 10	TA450/TA450A or TA4505	TA450/TA450A or TA4504
<b>VAN HOOL BUS</b>		
Some Models	TAB10076	
<b>VOLKSWAGEN</b>		
Models with male threads on filler neck, 1975-1993 Models with female threads on filler neck, 2004-current	TA168/TAB10022  TA41/TAB10041	TA23A  TA40
Beetle 1998-current Cabrio 1995-2002 Corrado 1990-1994 Eurovan 1993-2003 Golf 1985-1990 1991-1999 2000-current	TA41/TAB10041  TA31A/TAB10031  TA31A/TAB10031  TA31A/TAB10031  TA168/TAB10022 TA31A/TAB10031 TA41/TAB10041	TA40  TA30A  TA30A  TA30A  TA23A TA30A TA40

Make/Model/Year	Cooling System Adapter	Cap Adapter
<b>VOLKSWAGEN (CONTINUED)</b>		
CC 2009-current	TA41/TAB10041	TA40
GTI 1985-1990 1991-1999 2000-current	TA168/TAB10022 TA31A/TAB10031 TA41/TAB10041	TA23A TA30A TA40
Jetta 1980-1990 1991-1999 1999-current	TA168/TAB10022 TA31A/TAB10031 TA41/TAB10041	TA23A TA30A TA40
Passat 1990-1997 1998-current	TA31A/TAB10031 TA41/TAB10041	TA30A TA40
Phaeton 2002-current	TAB10074	
Toureg 2004-current	TA41/TAB10041	TA40
<b>VOLVO</b>		
All with threaded neck except large trucks and as specified below	TA188/TAB10025	TA26A
C30 2008-current C70 2008-current S40 2004-2011 S80 2008-current V50 2005-2011 V60 2014-current V70 2008-2010 XC60 2010-current XC70 2008-current	TA52/TAB10052  TA52/TAB10052  TA52/TAB10052  TA52/TAB10052  TA52/TAB10052  TA52/TAB10052  TA52/TAB10052  TA52/TAB10052  TA52/TAB10052	TA53  TA53  TA53  TA53  TA53  TA53  TA53  TA53
<b>Volvo Large Trucks with:</b> • 48mm x 3mm thread • 63mm x 3mm thread	TA50/TAB10022 TA27/TAB10027	TA23A

# COOLING SYSTEM ADAPTER GASKET APPLICATION GUIDE

Most Adapter Replacement Gaskets and O-Rings are available in kit form. Order Snap-on part # TAGASKETA. Some gaskets are available separately. See chart below for gasket applications and availability.

ADAPTER	GASKET/O-RING SIZE	GASKET PART #
TA32A	2 1/16" O.D. x 1 1/8" I.D. x 1/8" thick	Consult your Snap-on Franchisee
TA34A, TA36GM	2 1/16" O.D. x 1 7/16" I.D. x 1/8" thick	TAGASKETA
TA16B, TA18B, TA50, TAB10036, TAB10034	1 7/8" O.D. x 1 3/16" I.D. x 1/8" thick	TAGASKETA
TA245A, TA345A, TAB10245, TAB10345	1 7/16" O.D. x 15/16" I.D. x 1/16" thick	TAGASKETA
SVT262-28, SVT262-28A, TA38B, TA38C	1 1/8" O.D. x 1/2" I.D. x 1/4" thick	SVT262-30
TA31A, TA41, TAB10031, TAB10041	36mm O.D. x 28mm I.D. x 4mm cross section O-ring	TAGASKETA
TA36GM, TA46, TA52, TAB10036, TAB10046, TAB10052	31mm O.D. x 23mm I.D. x 4mm cross section O-ring	TAGASKETA
TA44, TAB10044	42mm O.D. x 34mm I.D. x 4mm cross section O-ring	TAGASKETA
TA48, TAB10048	13/16" O.D. x 5/8" I.D. x 3/32" cross section O-ring (O-ring # P16)	TAGASKETA
TA445, TAB10445	38mm O.D. x 28mm I.D. x 5mm cross section O-ring	Consult your Snap-on Franchisee
TA27, TA54	2 1/2" O.D. x 1 9/16" I.D. x 1/8" thick	Consult your Snap-on Franchisee
TA56, TAB10056	23mm O.D. x 17mm I.D. x 3mm cross section O-ring	Consult your Snap-on Franchisee
TA4503	2 3/4" O.D. x 1 3/4" I.D. x 3/16" thick	TA4502
TA450/TA450A/TA405	Molded Rubber Gasket	TA450-1A
TAB10025	1 11/16" O.D. x 1 1/16" I.D. x 1/8" thick	Consult your Snap-on Franchisee
TAB10022	1 3/4" O.D. x 1" I.D. x 1/8" thick	Consult your Snap-on Franchisee
TA58	27mm O.D. x 21mm I.D. x 3mm cross section O-ring	Consult your Snap-on Franchisee
TA60	Molded Gasket	Consult your Snap-on Franchisee
TA63, TAB10063	1 7/16" O.D. x 1 3/16" I.D. x 1/8" cross section O-ring	Consult your Snap-on Franchisee

## VACUUM ASSIST COOLING SYSTEM REFILLERS SVTSRAD262A and SVTSRAD262U Parts Diagram

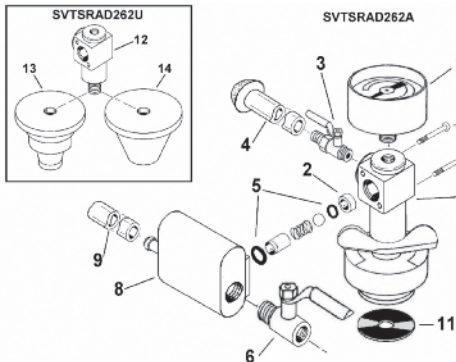

### SVTSRAD262A and SVTSRAD262U

DIAGRAM #	STOCK PART#	DESCRIPTION
*	SVTSRAD26230	Plastic Carrying Case (Not Shown)
1	SVTSRAD2626	Vacuum Gauge
2	SVTSRAD26211	Coolant Refill Body Sleeve
3	SVTSRAD26213	Coolant Refill Valve Assembly
4	SVTSRAD26221	Coolant Refill Hose Assembly with Screen
5	SVTSRAD26212	Inner Valve Assembly (Includes: Spring, Ball, Sleeve, O-Rings)
6	SVTSRAD26214	Air Inlet Valve
7	SVTSRAD26216	Assy. Screws, 8/32 x 1 1/4" (2 Req.)
8	SVTSRAD26215	Venturi Body
9	SVTSRAD2624	Overflow Hose
*	SVTARAD2621-15	15' hose and screen (not shown) Ideal for trucks!

### SVTSRAD262A ONLY

10	SVTSRAD26217	Coolant Refill Body Assembly
11	SVT262-19	Tester Seal

### SVTSRAD262U ONLY

12	SVTSRAD26227	Coolant Refill Body Assembly
13	SVTSRAD26228	Adapter Cone, Small (3/8-24 thread)
14	SVTSRAD26229	Adapter Cone, Large (3/8-24 thread)

**PARTS LIST for PRESSURE TESTER  
SVTS262C WITH ADAPTERS**

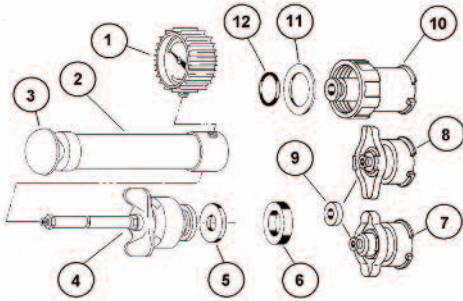

DIAGRAM #	STOCK PART#	DESCRIPTION
*	SVTS262-1	Cooling System Tester Pump (Diagram #1 - 5) - Packed in a cardboard box.
NOT SHOWN	SVT262-23	Plastic Carrying Case
1	SVTS263-2	Heavy Duty Pressure Gauge with Rubber Boot
2	SVT26232	Pump Assembly with Knob (gauge not included)
3	SVT261-3	Knob Only
4	SVT26233	Tester Head with Hose Assembly <b>NOTE: Hose may be field repaired - use 3/16" ID fuel hose</b>
5	SVT262-19	Tester Seal
6	SVT262-22	Spacer Washer (1/4" thick rubber washer for 1" deep filler necks-see page 7)
7	SVT262-28A	32 mm x 16mm deep Radiator Adapter with Seal, Silver
8	TA38C	32 mm x 9.5mm deep Radiator Adapter with Seal, Gold
9	SVT262-30	Rubber Seal for 32mm Radiator Adapters
10	TAB10036	Radiator Adapter with Seal
11	TAGASKETA	Rubber Seal for #TAB10036
12	TAGASKETA	Rubber O-Ring for #TAB10036

**PARTS LIST for PRESSURE TESTER  
SVTS272 WITH PARTS**

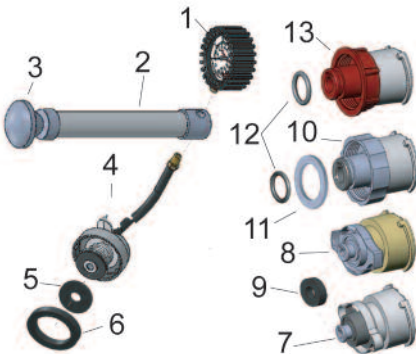

DIAGRAM #	STOCK PART#	DESCRIPTION
*	SVTS272-1	Cooling System Tester Pump (Diagram #1 - 5) - Packed in a cardboard box.
NOT SHOWN	SVT262-23	Plastic Carrying Case
1	SVTS263-2	Heavy Duty Pressure Gauge with Rubber Boot
2	SVTS27232	Pump Assembly with Knob (gauge not included)
3	SVT261-3	Knob Only
4	SVTS27233	Tester Head with Hose Assembly <b>NOTE: Hose may be field repaired - use 3/16" ID fuel hose</b>
5	SVT262-19	Tester Seal
6	SVT262-22	Spacer Washer (1/4" thick rubber washer for 1" deep filler necks-see page 7)
7	SVT262-28A	32 mm x 16mm deep Radiator Adapter with Seal, Silver
8	TA38C	32 mm x 9.5mm deep Radiator Adapter with Seal, Gold
9	SVT262-30	Rubber Seal for 32mm Radiator Adapters
10	TAB10036	Radiator Adapter with Seal
11	TAGASKETA	Rubber Seal for #TAB10036
12	TAGASKETA	Rubber O-Ring for #TAB10036/TAB10052
13	TAB10052	Radiator Adapter with Seal

**PARTS LIST for PRESSURE TESTER  
SVTS263A WITH PARTS**

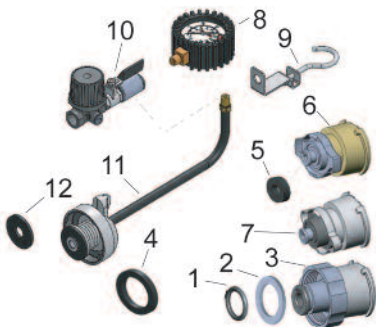
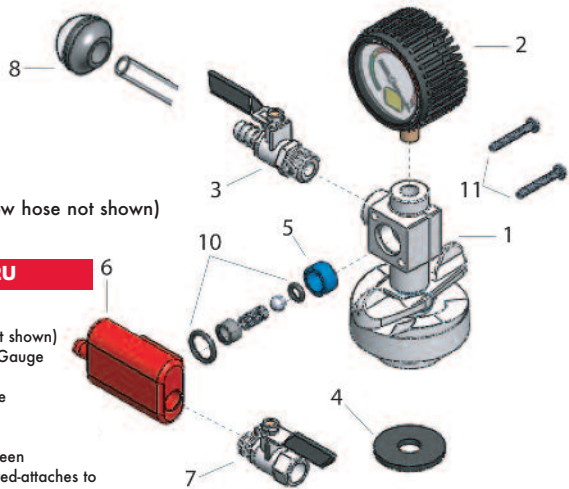

DIAGRAM #	STOCK PART #	DESCRIPTION
1	TAGASKETA	Set of O-rings and Gaskets
2	TAGASKETA	Set of O-rings and Gaskets
3	TAB10036	Radiator Adapter with Seal
4	SVT262-22	Spacer Washer (1/4" Thick Rubber Washer) for testing 1" Deep Filler Necks
5	SVT262-30	Rubber Seal for 32mm Radiator Adapters
6	TA38C	32 mm x 9.5mm deep, adapter with seal
7	SVT262-28A	32 mm x 16mm deep, adapter with seal
*	SVTS263-1	Complete pump with Hose and Cap Assy. (#8 thru #12)
8	SVTS263-2	Pressure Gauge with rubber boot
9	SVTS263-3	Hook and Bracket Assembly
10	SVTS263-6	Valve/Regulator Assembly
11	SVTS263-4	Cap Assembly with Hose <b>Note: Hose is field repairable with 3/16" fuel hose.</b>
12	SVT262-19	Tester Seal
*	SVTS263-5	(Not Shown) Plastic Carrying Case

**LIMITED WARRANTY**

Any Snap-on equipment item shown in this booklet which fails to give satisfactory service within the one year warranty period will be repaired or replaced when returned to a Snap-on representative. Snap-on shall not be liable for loss of use of the product or other incidental or consequential costs incurred by the purchaser.

# SVTSRAD272A AND SVTSRAD272U COOLANT REFILLERS



## SVTSRAD272A and SVTSRAD272U

DIAGRAM #	STOCK PART#	DESCRIPTION
*	SVTSRAD26230	Plastic Carrying Case (not shown)
2	SVTSRAD2726	Bottom Connect Vacuum Gauge
3	SVTSRAD27213	Coolant Refill Valve
5	SVTSRAD26211	Coolant Refill Body Sleeve
6	SVTSRAD26215	Venturi Body Assembly
7	SVTSRAD26214	Air Inlet Valve
8	SVTSRAD2721	Coolant Refill Hose w/screen
9	SVTSRAD2624	Overflow hose (not pictured-attaches to end of Venturi body)
10	SVTSRAD26212	Inner Valve Assembly
11	SVTSRAD26216	Assy. Screws, 8/32" x 1 1/4" (2 Req.)
15	SVTSRAD27215	Coolant Refill Suction Screen Only

## SVTSRAD272A ONLY

1	SVTSRAD27217	Coolant Refill Body Assembly
4	SVT262-19	Tester Seal

## SVTSRAD272U ONLY

12	SVTSRAD27227	Coolant Refill Body Assembly
13	SVTSRAD27229	Adapter Cone, Smooth (7/16-20 thread)
14	SVTSRAD27228	Adapter Cone, Step (7/16-20 thread)

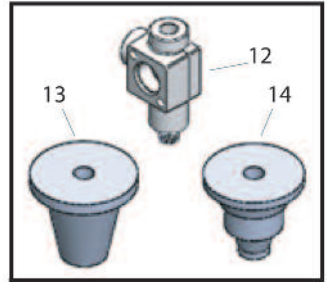

# SVTSRAD372T TRUCK COOLANT REFILLER

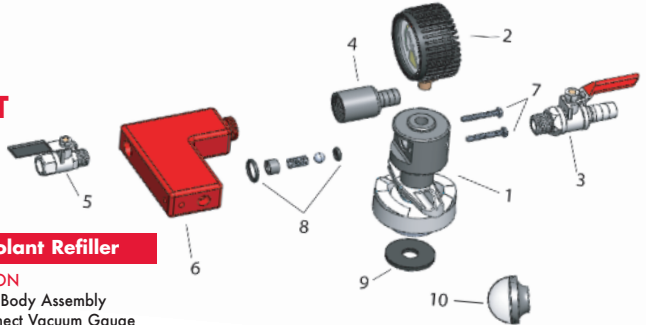

## SVTSRAD372T Truck Coolant Refiller

DIAGRAM #	STOCK PART#	DESCRIPTION
1	SVTSRAD3727	Truck Refill Body Assembly
2	SVTSRAD2726	Lower Connect Vacuum Gauge
3	SVTSRAD3722	Coolant Refill Valve
4	SVTSRAD3723	Exit Nozzle
5	SVTSRAD26214	Air Inlet Valve
6	SVTSRAD3725	Venturi Body
7	SVTSRAD26216	Assy. Screws, 8/32" x 1 1/4" (2 Req.)
8	SVTSRAD37212	Truck Inner Valve Assembly
9	SVT262-19	Tester Seal
10	SVTSRAD37215	Domed screen (attaches on end of refill hose)
*	SVTSRAD3725	Venturi Hose (attaches to exit nozzle)
*	SVTSRAD3721	Coolant Refill Hose with Domed Screen (attaches to refill valve)
*	SVTSRAD37230	Plastic Carrying Case

\*NOT PICTURED

Made in the U.S.A. with global components.  
 Snap-on and Blue-Point are trademarks of Snap-on Incorporated.  
 © Snap-on Incorporated 2016. Printed in U.S.A.  
 2801 80th St., Kenosha, WI 53143 www.snapon.com